

SUN2000-12/15/17/20KTL-M2 (High Current Version) Smart PV Controller



Active Safety

AI Powered Arcing Protection



Higher Yields

Up to 30% More Energy with Optimizer



Flexible Communication

WLAN, Fast Ethernet, 4G
Communication Supported

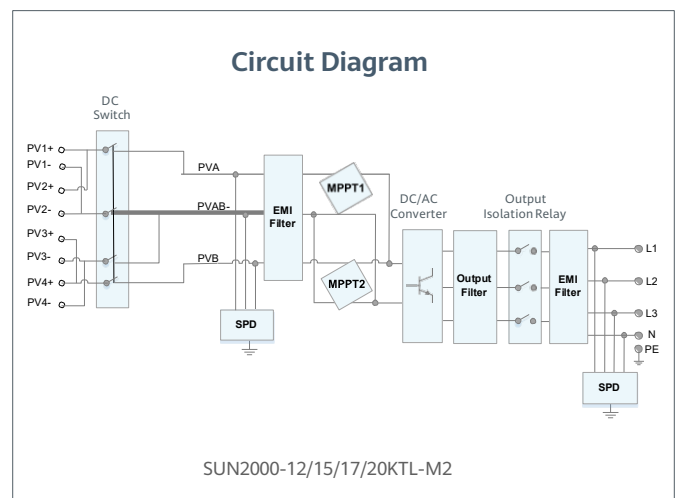
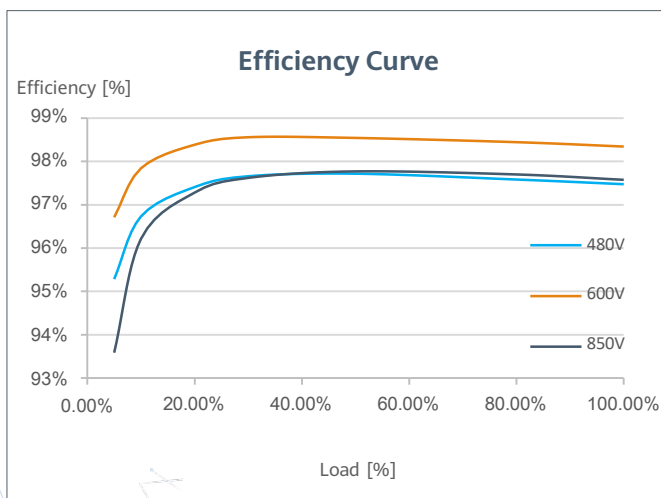

SUN2000-12/15/17/20KTL-M2 (High Current Version) Technical Specification

Technical Specification	SUN2000 -12KTL-M2	SUN2000 -15KTL-M2	SUN2000 -17KTL-M2	SUN2000 -20KTL-M2
-------------------------	----------------------	----------------------	----------------------	----------------------

Efficiency

Max. efficiency	98.50%	98.65%	98.65%	98.65%
European weighted efficiency	98.00%	98.30%	98.30%	98.30%

Input

Recommended max. PV power ¹	18,000 Wp	22,500 Wp	25,500 Wp	30,000 Wp
Max. input voltage ²	1,080 V			
Operating voltage range ³	160 V ~ 950 V			
Start-up voltage	200 V			
Rated input voltage	600 V			
Max. input current per MPPT	27 A (per MPPT) / 18 A (per Input) ⁴			
Max. short-circuit current	39 A			
Number of MPP trackers	2			
Max. number of inputs	4			

Output

Grid connection	Three phase			
Rated output power	12,000 W	15,000 W	17,000 W	20,000 W
Max. apparent power	13,200 VA	16,500 VA	18,700 VA	22,000 VA
Rated output voltage	220 Vac / 380 Vac, 230 Vac / 400 Vac, 3W + N + PE			
Rated AC grid frequency	50 Hz / 60 Hz			
Max. output current	20 A	25.2 A	28.5 A	33.5 A
Adjustable power factor	0.8 leading ... 0.8 lagging			
Max. total harmonic distortion	≤ 3 %			

Features & Protections

Input-side disconnection device	Yes
Anti-islanding protection	Yes
AC over-current protection	Yes
AC short-circuit protection	Yes
AC over-voltage protection	Yes
DC reverse-polarity protection	Yes
DC surge protection	TYPE II
AC surge protection	Yes, compatible with TYPE II protection class according to EN/IEC 61643-11
Residual current monitoring unit	Yes
Arc fault protection	Yes
Ripple receiver control	Yes
Integrated PID recovery ⁵	Yes

General Data

Operation temperature range	-25 ~ +60 °C (-13 °F ~ 140 °F)
Relative humidity	0 % RH ~ 100% RH
Max. operating altitude	0 ~ 4,000 m (13,123 ft.) (Derating above 2000 m)
Cooling	Natural Convection
Display	LED Indicators; Integrated WLAN + FusionSolar App
Communication	RS485; WLAN/Ethernet via Smart Dongle-WLAN-FE (Optional) 4G / 3G / 2G via Smart Dongle-4G (Optional)
Weight (with mounting plate)	25 kg
Dimensions (W x H x D) (incl. mounting plate)	525 x 470 x 262 mm (20.7 x 18.5 x 10.3 inch)
Degree of protection	IP65
Nighttime Power Consumption	< 5.5W ⁶

Optimizer Compatibility

DC MBUS compatible optimizer	SUN2000-450W-P, SUN2000-450W-P2, SUN2000-600W-P
------------------------------	---

Standard Compliance (more available upon request)

Safety	EN/IEC 62109-1, EN/IEC 62109-2
Grid connection standards	G98, G99, EN 50549, CEI 0-21, CEI 0-16, VDE-AR-N-4105, VDE-AR-N-4110, AS 4777.2, C10/11, ABNT, VFR 2019, RD 1699, RD 661, PO 12.3, TOR D4, IEC61727, IEC62116, DEWA

¹ Inverter max input PV power is 40,000 Wp when long strings are designed and fully connected with SUN2000-450W-P power optimizers.

² The maximum input voltage is the upper limit of the DC voltage. Any higher input DC voltage would probably damage inverter.

³ Any DC input voltage beyond the operating voltage range may result in inverter improper operating.

⁴ The MPPT voltage of each PV string must exceed the lower limit of Full Power MPPT Voltage Range. (Full Power MPPT Voltage Range: 12KTL@360~850V, 15KTL@380~850V, 17KTL@400~850V, 20KTL@450~850V)

⁵ SUN2000-12~20KTL-M2 raises potential between PV- and ground to above zero through integrated PID recovery function to recover module degradation from PID. Supported module types include: P-type (mono, poly)

⁶ <10W when PID recovery function is activated

⁷ Smart IV Curve Diagnosis feature will be made available in a future firmware upgrade, which expected available 2021 Q4